

TITAN

UNBEATEN AT MARGINAL
TEMPERATURES AND LOW PRESSURE

 **DEMACLENKO**

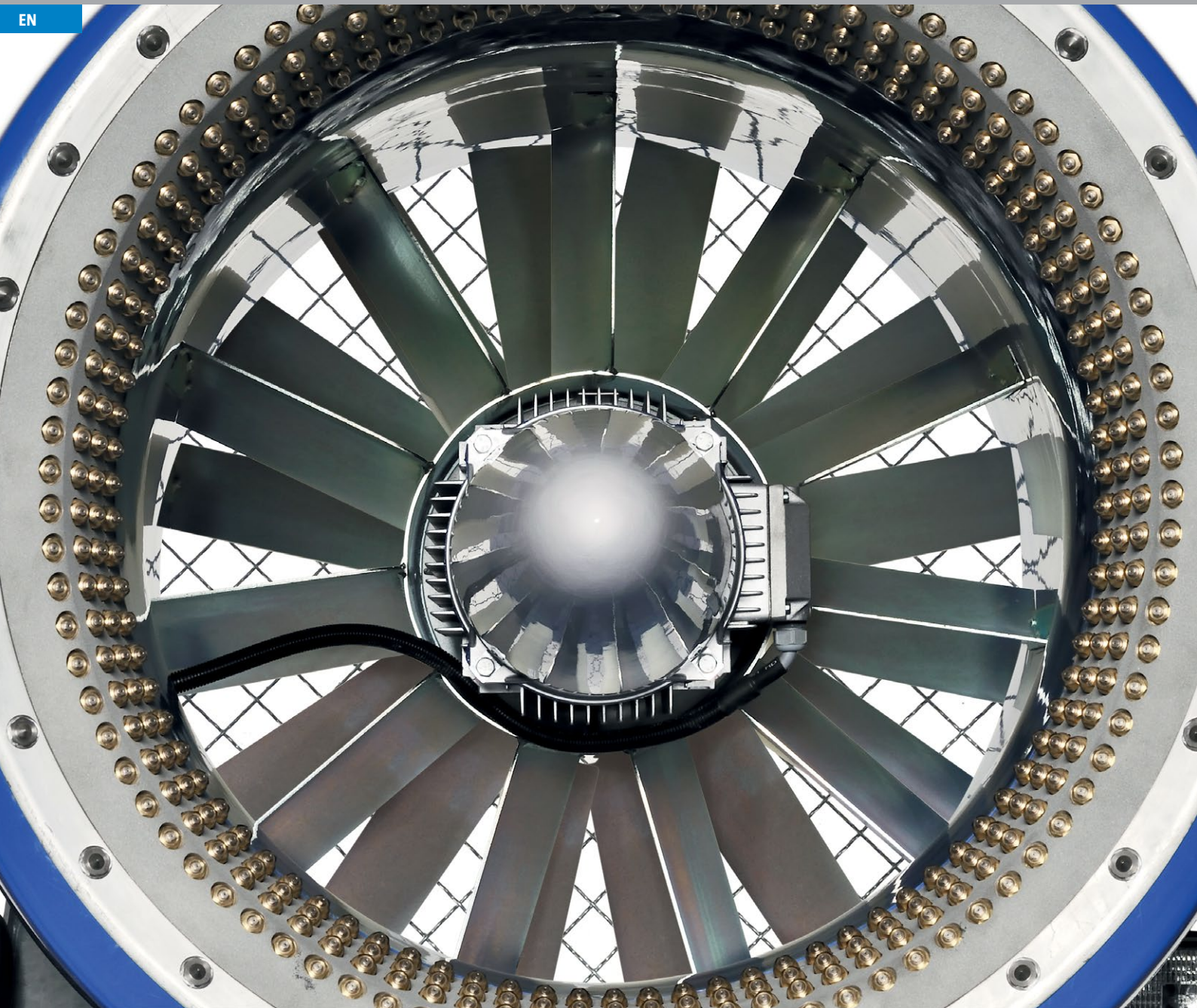





TITAN X

THE LEADER IN MARGINAL
TEMPERATURES.
STATE-OF-THE-ART DESIGN.
FIRST-CLASS SNOW OUTPUT.

TITAN X stands for high-quality materials, sophisticated technology and low maintenance components.

SNOW PRODUCTION

MAXIMUM



- 1 **FRP** (fiberglass composite) - barrel with aluminum nozzle ring
- 2 **"Multi-nozzle"**- system
- 3 **7" touch screen** user interface with optional usage of an app compatible with smartphones/tablets via wireless connection
- 4 **Valve unit** with self-draining and central water inlet
- 5 Oil-free **compressor**



TITAN X

TECHNICAL HIGHLIGHTS

- > A compact **zinc coated steel chassis** which stands steady on the slope and is fitted with three steel legs and wheels
- > **FRP (fiberglass composite)** – barrel with aluminum nozzle ring
- > Stainless steel **water nozzles** and brass alloy **nucleators**
- > Manual or electrical **rotation 360°**
- > Barrel inclination adjustable manually or electrically between **0° and 45°**
- > **Electrical cabinet** with IP55 protection standard
- > **Valve unit** with self-draining and central **water inlet**
- > Oil-free **compressor** (oil compressor optional)
- > Warning and **spotlight**
- > Easily accessible **water filter**
- > **Softstart for fan motor**
- > **Wind chasing function** available with **snowVisual** integration (valid for AT/ATK and AS/ASK)
- > Forced **ventilated temperature sensor**

AUTOMATIC FUNCTIONS

- > Oscillation from 10° to 330°
- > **7" touch screen** user interface with optional usage of an app compatible with smartphones/tablets via wireless connection
- > **Display** showing current data regarding water temperature, water pressure, water flow, snow quality, air temperature and humidity, electrical consumption as well as all statistical data
- > Alarm which **automatically** stops the fan gun
- > Display of **alarm list** for easy adjustment
- > **multilanguage** software

CONFIGURATIONS

- > **TITAN X MMK** manual mobile fan gun with compressor
- > **TITAN X AMK** automatic mobile fan gun with compressor
- > **TITAN X AT and ATK** with or without compressor mounted on fixed tower
- > **TITAN X AS and ASK** with or without compressor mounted on winch tower
- > **TITAN X AXK** on arm



TITAN X MMK



TITAN X AMK



TITAN X AT/ATK



TITAN X AS/ASK

TECHNICAL DETAILS

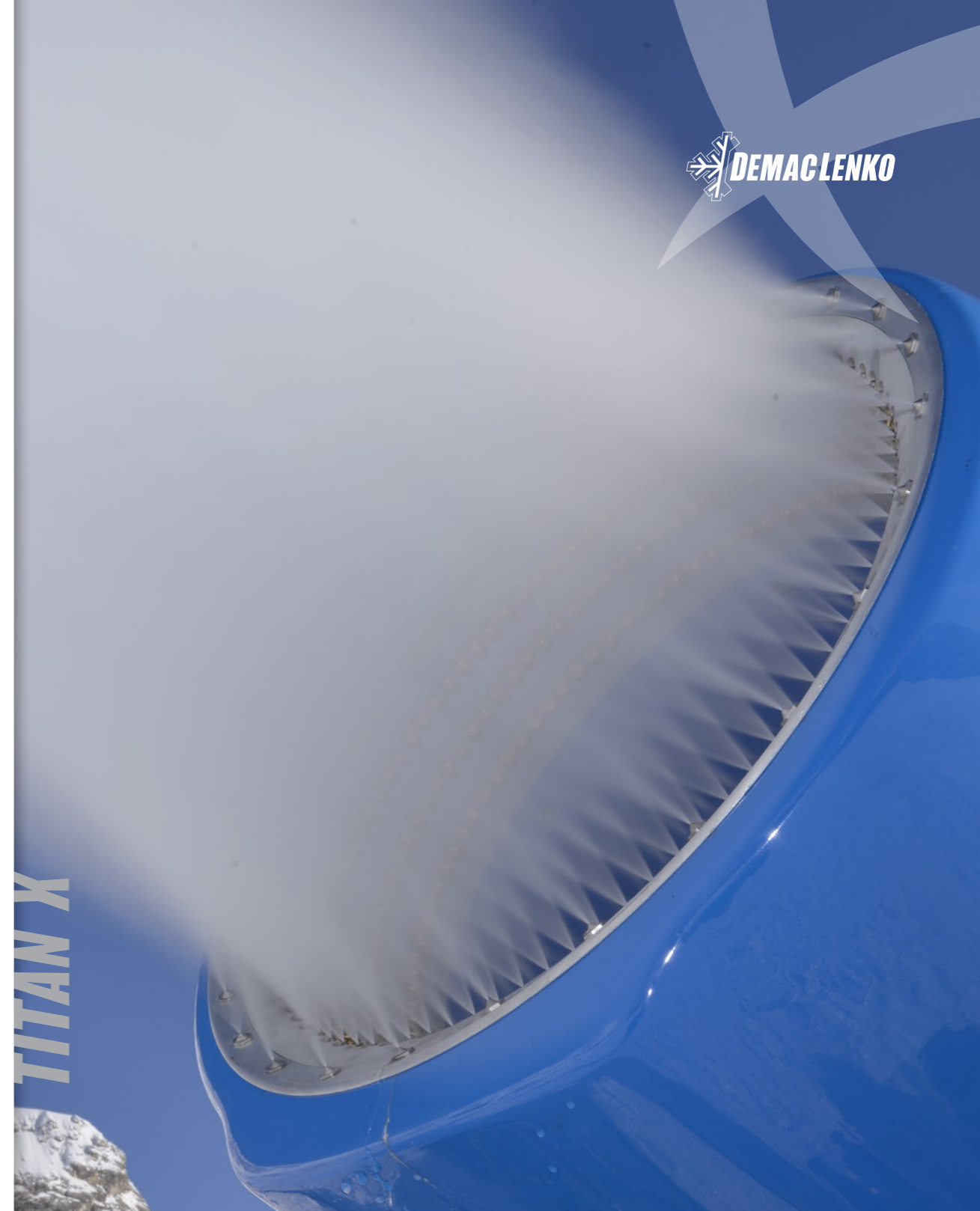

DEMAGLENKO



TECHNICAL DATA

Height (A)	2.575 mm (8ft 5in)*
Length (B)	2.090 mm (6ft 10in)*
Width (C)	1.890 mm (6ft 2in)*
Fan gun with legs and cable	773 kg (1,704 lbs)*
Wheel and drawbar	85 kg (187 lbs)
Nominal voltage	400/440/480 V
Fan	18,5 kW (24.1 HP)
Compressor	4 kW (5.4 HP)
Heating	3 kW (4 HP)
Total input power	25,5 kW (33.5 HP)
Nominal frequency	50/60 Hz
Connection plug	63 A
Nucleators	27
Water nozzles	360
Swinging range	360°
Automatic swing	10°-330°
Barrel inclination	0°-45°
Connection water	2"
Operation water pressure	8-40 bar (116-580 psi)
Water filter	200 micron
Maximal water flow	9,6 l/s (152.2 gpm)
Maximal snow production	92 m ³ /h (120 yd ³ /h)
Throwing range	70 m (230 ft)

*only for TITAN X AMK

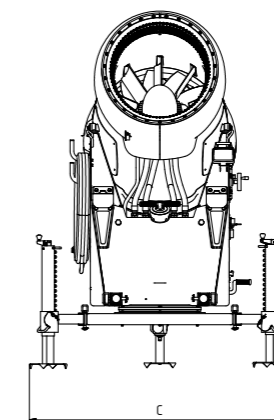
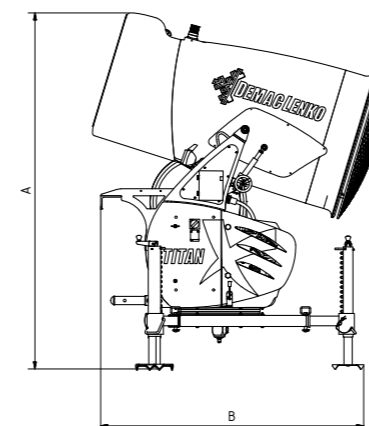

TITAN X

TECHNICAL DATA

DEMACLENKO AUSTRIA GmbH

Michael-Seeber-Straße 1
A-6410 Telfs
Tel. +43 5262 621 21 3403
Fax +43 5262 621 21 3400
sales.austria@demaclenko.com

DEMACLENKO IT Srl/ GmbH

Griesbruck 14/B - Neidegg
I-39043 Klausen
Tel. +39 0472 061601
Fax +39 0472 061649
sales.italy@demaclenko.com

DEMACLENKO FRANCE - LEITNER FRANCE SAS

Voie Galilée - Zone d'activité d'Alpespace - CS 50001
F-73802 Montmelian Cedex
Tel. +33 (0)4 79 84 77 77
Fax +33 (0)4 79 84 77 00
sales.france@demaclenko.com

DEMACLENKO SWITZERLAND GmbH

Im Ehrmerk 11
8360 Wallenwil
Tel. +41 71 9714866
Fax +41 71 9712870
sales.switzerland@demaclenko.com

DEMACLENKO AMERICA Inc

264 NH Route 106
Gilmanton, NH 03237
Tel. +1 603 267 7840
Fax +1 603 267 7843
sales.usa@demaclenko.com

DEMACLENKO AMERICA Inc

2746 Seeber Drive
Grand Junction, US 81506
Tel. +1 970 241 442
sales.usa@demaclenko.com



www.demaclenko.com

